

# Series e-1532 Pumps

THE INDUSTRY STANDARD IN END SUCTION PUMP DESIGN  
TECHNICAL BROCHURE

# Series e-1532 Close-Coupled Pumps

## Standard Design Features

- 1. Internally Flushed Mechanical Seals** ensure maximum seal face lubrication, heat dissipation and debris removal without vulnerable, external flush tubing. As much as 25 percent of the total pump flow continuously flushes the seal faces.
- 2. Back Pull-out** design allows one service tech ease of maintenance.
- 3. Stainless Steel Shaft Sleeve** construction is standard. Special sealing between the sleeve and shaft prevents corrosion of the shaft by the pumped fluid.
- 4. ISO G6.3 Balanced Impeller** for quiet, vibration free performance. Impellers are precision fitted to the shaft and positively locked with a shaft key.
- 5. Heavy Duty Cast Iron Footed Volute** construction for 175 PSI working pressure.
- 6. Jacking bolts** provide ease of volute disassembly.
- 7. Gauge tappings** on the suction and discharge flanges along with volute vent and drain tappings are standard.
- 8. Hydrostatic testing** of each pump is standard.

## Pump Options

- Stainless Steel Volute Wear Ring
- External Flush Line
- Stuffing Box Configuration
- Epoxy Coated Internal Cast Iron Components
- Special Impeller Balancing (ISO 1940 G2.5 or G1.0)
- Certified Performance Tests (Per HI Standard 14.6)
- Heavy Duty Baseplate
- Galvanized Steel Drip Pan

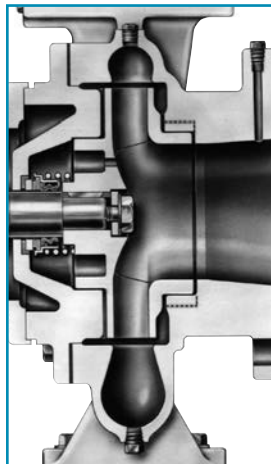

Standard Configuration

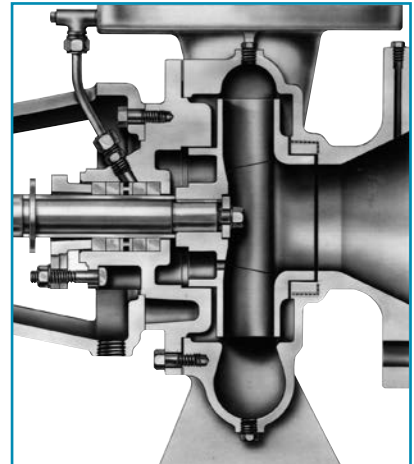

Stuffing Box Configuration

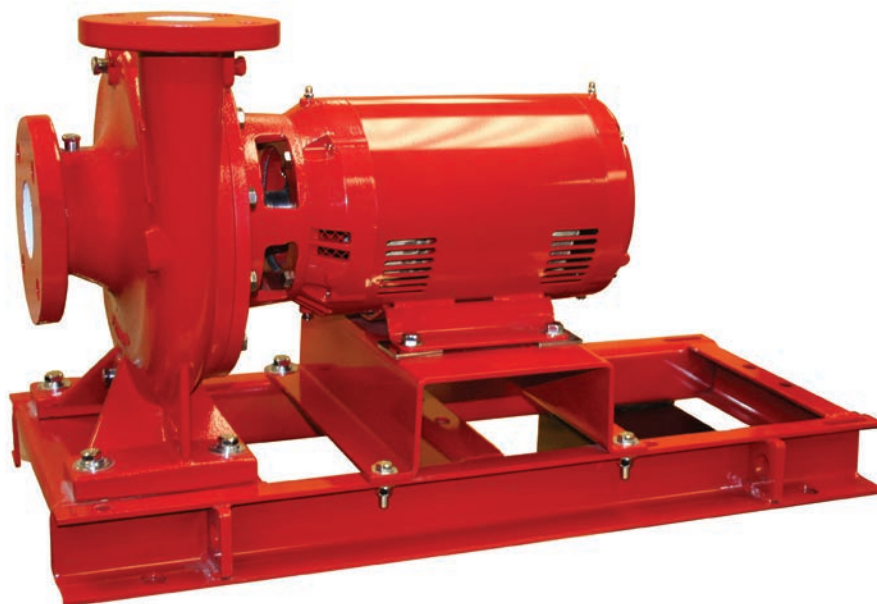

## Series e-1532 Materials of Construction

Description	Stainless Steel Fitted
1 Shaft	Carbon Steel Grade per Motor Manufacturer
2 Volute	Cast Iron ASTM A48 Class 30B
3 Impeller	ASTM A743 Grade CF8 - 304 Stainless Steel
4 Shaft Sleeve	ASTM 312 Grade TP304 - 304 Stainless Steel
5 Impeller Key	#304 Stainless Steel
6 Impeller Washer	Steel
7 Impeller Lock Washer	#304 Stainless Steel
8 Impeller Cap Screw	#304 Stainless Steel
9 Volute Gasket	Cellulose Fiber
10 Seal Assembly	Reference Tables Below

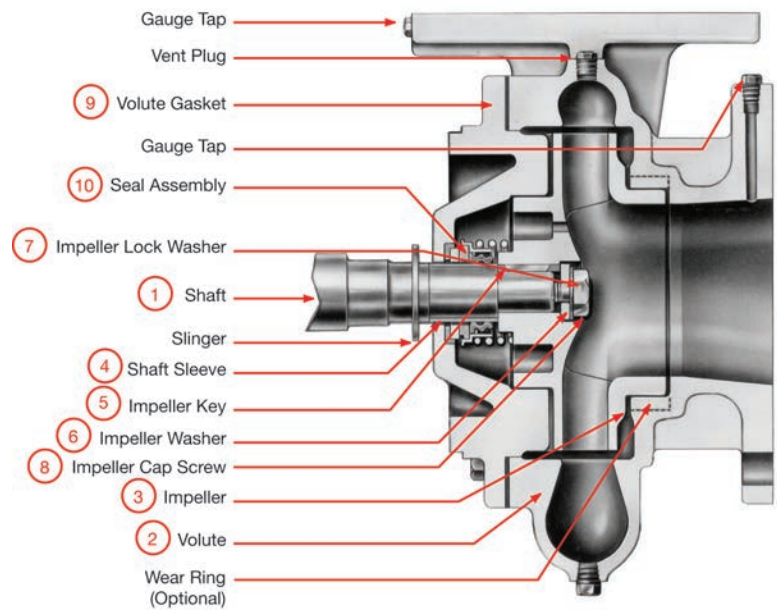

## Standard Mechanical Configuration

Standard Mechanical Seal	
Temperature Range	-20 to 225°F
Maximum Pressure	175 PSI
pH Limitations	7.0 - 9.0
Elastomer	Buna
Rotating Face	Carbon
Stationary Face	Ceramic
Hardware	Stainless Steel / Brass

Mechanical Seal Options			
Temperature Range	-20 to 250°F	-10 to 225°F	-20 to 250°F
Maximum Pressure	175 PSI	175 PSI	175 PSI
pH Limitations	7.0 - 11.0	7.0 - 9.0	7.0 - 12.5
Elastomer	EPR (Ethylene Propylene Rubber)	FKM (Viton™ or Fluoroelastomer)	EPR (Ethylene Propylene Rubber)
Rotating Face	Carbon	Carbon	Silicon Carbide
Stationary Face	Tungsten Carbide	Ceramic	Silicon Carbide
Hardware	Stainless Steel / Brass	Stainless Steel	Stainless Steel

## Stuffing Box Configuration

Mechanical Seal	
Temperature Range	-20 to 300°F*
Maximum Pressure	175 PSI
pH Limitations	7.0 - 11.0
Elastomer	EPR (Ethylene Propylene Rubber)
Rotating Face	Tungsten Carbide
Stationary Face	Carbon
Hardware	Stainless Steel

Packing Option	
Temperature Range	0 to 250°F
Maximum Pressure	175 PSI
pH Limitations	7.0 - 9.0
Material	Braided Graphite Impregnated PTFE

\* For operating temperatures above 250°F a cooled flush is required and is recommended for temperatures above 225°F for optimum seal life. On closed systems cooling is accomplished by inserting a small heat exchanger in the flush line to cool the seal flushing fluid.

Flush-line Filters and Sediment Separators are available on special request.

# Series e-1532 Performance Curves

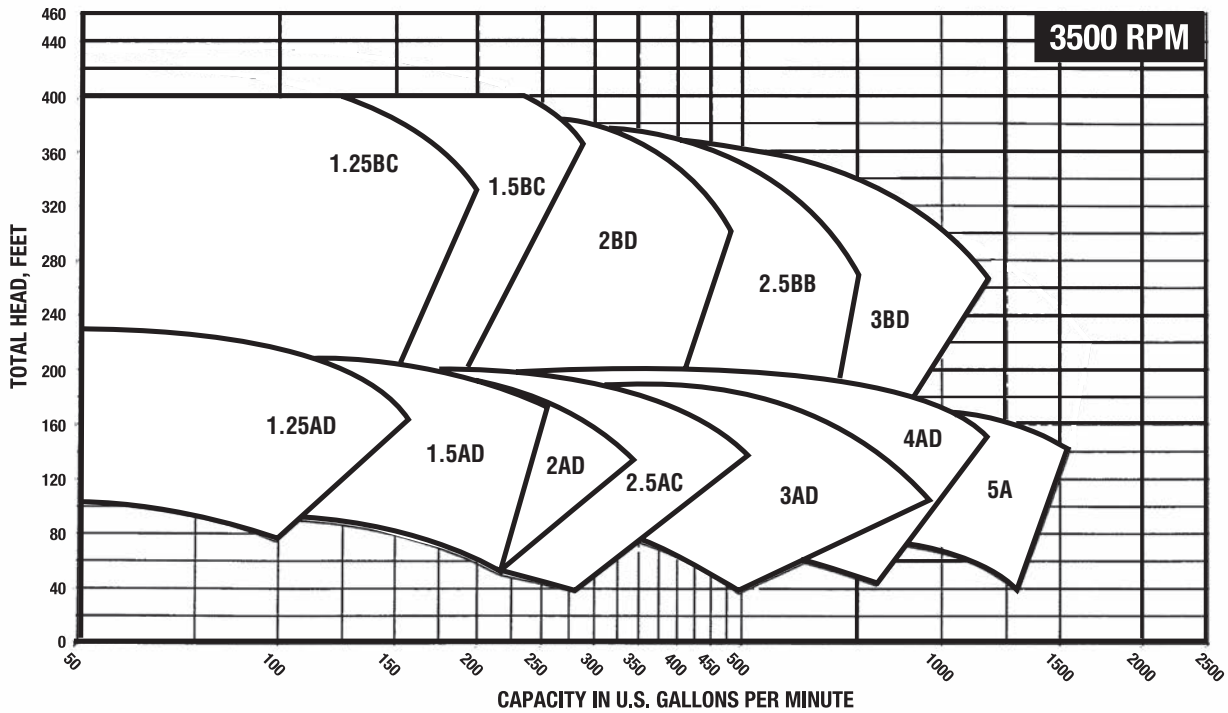
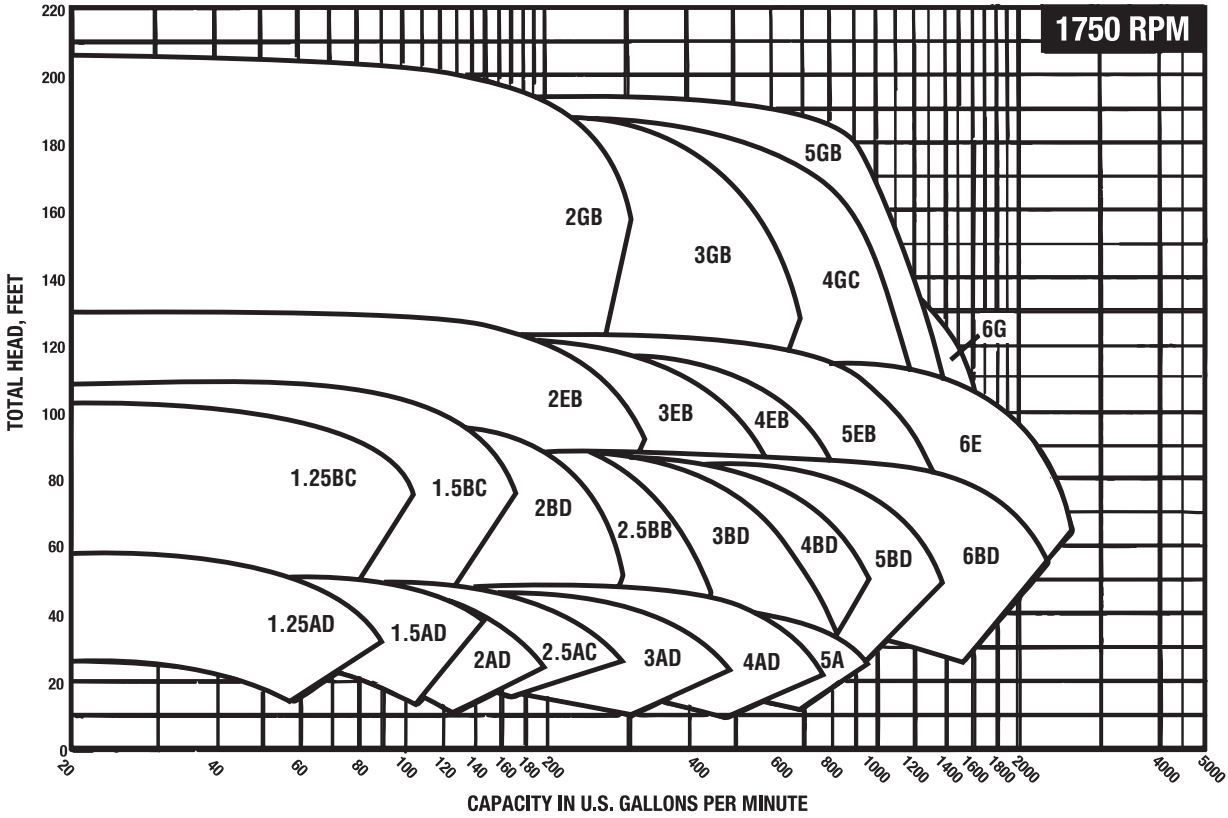

Xylem Inc.  
 8200 N. Austin Avenue  
 Morton Grove, Illinois 60053  
 Phone: (847) 966-3700  
 Fax: (847) 965-8379  
[www.bellgossett.com](http://www.bellgossett.com)

Bell & Gossett is a trademark of Xylem Inc. or one of its subsidiaries.  
 © 2014 Xylem Inc. B-312 January 2014